

X-TECH

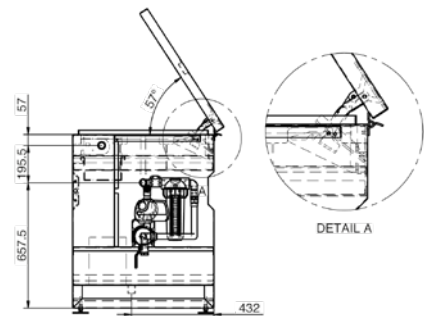

Mod. X-10 1000 liters' capacity

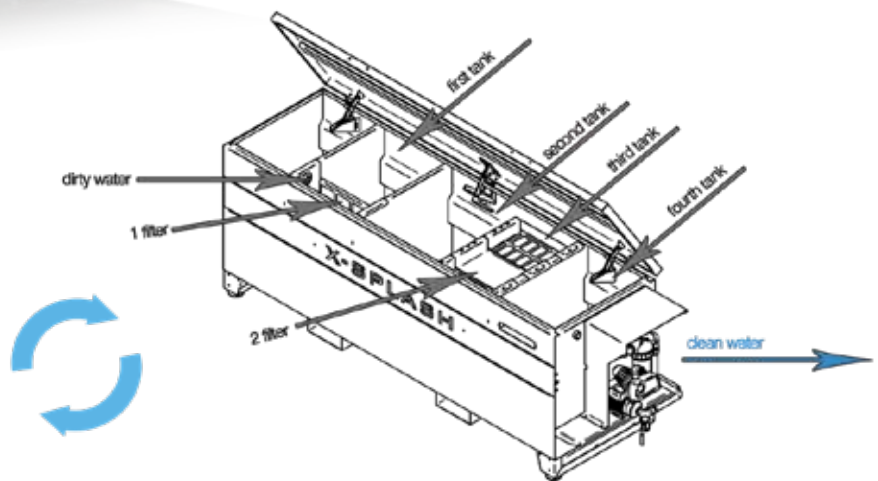

X-10

SEPARATION TANK SOLUTIONS Sewage treatment systems

- Dirty water is pumped in to the separation tank
- Is collected most of the mud
- Increase the filtering surface
- The filters separate the oil from water and hydrocarbons
- Water in the system is also cleaned up with replenished water from the mains, to cover any water lost
- The booster pump delivers the new clear water to your pressure washer



The water from the wash bay is typically made up by the presence of various types of pollutants, such as suspended solids (sands, muds, gravel, stone chips and other residues), detergents, oils and hydrocarbons. For this reason, the treatment of such waste water requires a series of filters needs to remove the pollutants.

In the Light Filtration Tank **X-10**, the first treatment is a sand trap, where through gravity, a separation of all those compounds which have a specific weight, different to water, will sink. These include sand, mud, gravel. They will sink and accumulate at the bottom of the tank, whilst the lighter materials (oils, etc) float to the top. The outlet pipe sucks the water from the middle point of the separator tank, preventing any overflow of the separated pollutants at the top and the bottom of the tank.

The second filtration step is to remove oil and hydrocarbons. This is done due to the gravity separation and later with an absorption filter, able to intercept the oil and hydrocarbons from the water. After this, the recycled water is pumped into the final separator tank and is considered clean and ready to be used again to wash down other equipment.

It should be remembered that the drains must be carried out by competent and authorised companies, as this type of waste can be considered dangerous, and must be disposed of as such.



Technical Specifications X-10

Dimension	2810 x 740 x 990h mm
Dry Weight	320 kg
Suction pump	0,054 kW - 17lt/min
Booster pump	0,37 kW - 5 to 40 lt/min